

**RIDGID
R29301 ROUTER
REPAIR SHEET**

**FEUILLE DE RÉPARATION
DE TOUPIE
RIDGID R29301**

**RIDGID
FRESADORA R29301
LISTA DE PIEZAS DE REPUESTO**



R2910 Fixed Base Assembly

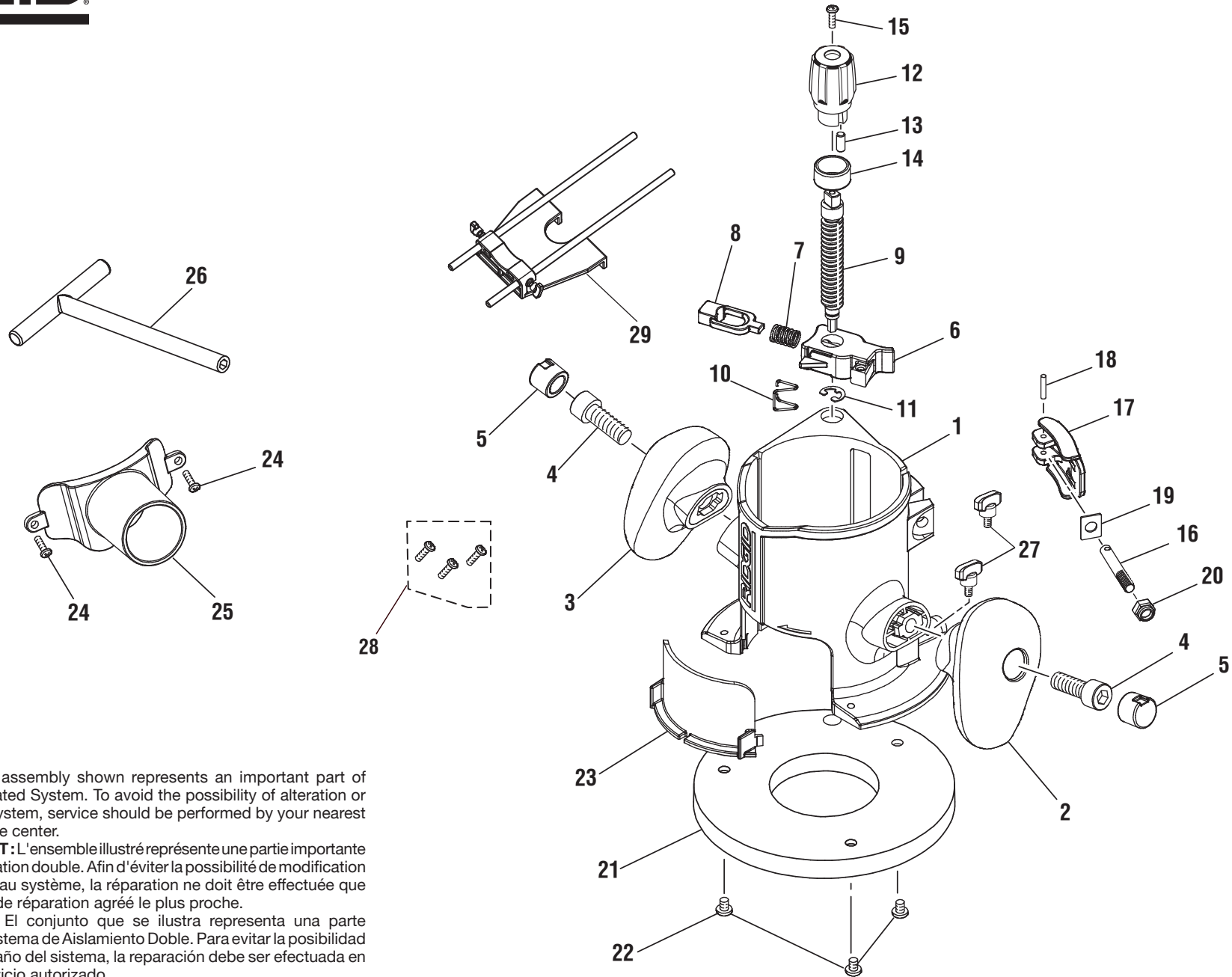

- ⚠ WARNING:** The assembly shown represents an important part of the Double Insulated System. To avoid the possibility of alteration or damage to the System, service should be performed by your nearest authorized service center.
- ⚠ AVERTISSEMENT :** L'ensemble illustré représente une partie importante du système à isolation double. Afin d'éviter la possibilité de modification ou de dommage au système, la réparation ne doit être effectuée que par votre centre de réparation agréé le plus proche.
- ⚠ ADVERTENCIA:** El conjunto que se ilustra representa una parte importante del Sistema de Aislamiento Doble. Para evitar la posibilidad de alteración o daño del sistema, la reparación debe ser efectuada en su centro de servicio autorizado.



R2910 Fixed Base Assembly/R2910 Base Fixe/R2910 Conjunto de la Base Fija

KEY	P/N	DESCRIPTION	QTY	PIÈCE	RÉF.	DESCRIPTION	QTÉ	REF.	N/P	DESCRIPCIÓN	CANT.
1	640925001	ROUTER BASE	1	1	640925001	BASE DE TOUPIE	1	1	640925001	BASE DE LA FRESADORA.	1
2	513347001	RIGHT HANDLE.....	1	2	513347001	POIGNÉE DROITE	1	2	513347001	MANGO DERECHO	1
3	513348001	LEFT HANDLE	1	3	513348001	POIGNÉE GAUCHE	1	3	513348001	MANGO IZQUIERDO	1
4	660053003	* BOLT (M10 X 28 mm SOC. HD.)	2	4	660053003	* BOULON (M10 X 28 mm à tête creuse.) ..	2	4	660053003	* PERNO (M10 X 28 mm CAB. HUECA)	2
5	513395001	HANDLE PLUG	2	5	513395001	BOUCHON DE POIGNÉE	2	5	513395001	TAPÓN DEL MANGO	2
6	640963002	ADJUSTMENT BAR	1	6	640963002	TIGE DE RÉGLAGE.....	1	6	640963002	BARRA DE AJUSTE.....	1
7	671758001	COMPRESSION SPRING	1	7	671758001	RESSORT	1	7	671758001	RESORTE.....	1
8	513396001	ADJUSTMENT BUTTON HOUSING	1	8	513396001	LOGEMENT DU BOUTON DE RÉGLAGE..	1	8	513396001	ALOJAMIENTO DEL BOTÓN DE AJUSTE..	1
9	671757001	HEIGHT ADJUSTMENT SCREW	1	9	671757001	VIS DE RÉGLAGE DE HAUTEUR.....	1	9	671757001	TORNILLO DE AJUSTE DE ALTURA	1
10	671759001	TORSION SPRING.....	1	10	671759001	RESSORT DE TORSION.....	1	10	671759001	RESORTE DE TORSIÓN	1
11	671797001	E-RING.....	1	11	671797001	CLIP EN E	1	11	671797001	ANILLO EN "E"	1
12	513093001	DEPTH ADJUSTMENT KNOB	1	12	513093001	BOUTON DE RÉGLAGE DE PROFONDEUR	1	12	513093001	PERILLA DE AJUSTE DE PROFUNDIDAD	1
13	570334001	RUBBER PLUG.....	1	13	570334001	BOUCHON EN CAOUTCHOUC	1	13	570334001	TAPÓN DE CAUCHO	1
14	340092001	ZERO RESET RING	1	14	340092001	BAGUE DE REMISE À ZÉRO.....	1	14	340092001	ANILLO DE AJUSTE A CERO	1
15	660440001	* SCREW (M3.5 X 12 mm).....	1	15	660440001	* VIS (M3,5 X 12 mm)	1	15	660440001	* TORNILLO (M3,5 X 12 mm).....	1
16	671260001	LEVER PIN	1	16	671260001	AXE DE LEVIER.....	1	16	671260001	PASADOR DE LA PALANCA.....	1
17	200276012	LOCK LEVER	1	17	200276012	LEVIER DE VERROUILLAGE	1	17	200276012	PALANCA DE FIJACIÓN	1
18	671247001	ROLL PIN	1	18	671247001	GOUPILLE CYLINDRIQUE.....	1	18	671247001	PASADOR DE ARTICULACIÓN	1
19	631421001	WEAR PLATE	1	19	631421001	PLAQUE D'USURE	1	19	631421001	PLACA DE ROZAMIENTO	1
20	671243001	STOP NUT	1	20	671243001	ÉCROU DE BLOCAGE.....	1	20	671243001	TUERCA DE SEGURIDAD	1
21	513087001	SUBBASE	1	21	513087001	SEMELLE.....	1	21	513087001	SUBBASE	1
22	660136002	* SCREW (10-32 X 3/8 in.).....	3	22	660136002	* VIS (10-32 X 9,5 mm [3/8 po])	3	22	660136002	* TORNILLO (10-32 X 9,5 mm [3/8 pulg.]) ...	3
23	513094001	CHIP SHIELD	1	23	513094001	PARE-COPEAUX.....	1	23	513094001	PROTECTOR CONTRA VIRUTAS	1
24	660284004	* VACUUM ADAPTOR SCREW (6-32 X 3/8 in. PAN HD.)	2	24	660284004	* VIS DE ADAPTATEURS DE SAC (6-32 X 9,5 MM [3/8 PO] TÊTE BOMBÉE). 2	2	24	660284004	* TORNILLO DE ADAPTADOR PARA ASPIRADORA (6-32 X 3/8 pulg. PAN HD.) 2	2
25	513349001	VACUUM ADAPTOR.....	1	25	513349001	ADAPTATEURS DE SAC	1	25	513349001	ADAPTADOR PARA ASPIRADORA.....	1
26	513667001	T-HANDLE WRENCH	1	26	513667001	CLÉ EN T	1	26	513667001	LLAVE DE MANGO EN "T"	1
27	512777001	GUIDE ADJUSTMENT KNOB	2	27	512777001	BOUTON DE RÉGLAGE DE GUIDE.....	2	27	512777001	PERILLA DE AJUSTE DE LA GUÍA	2
28	660235010	ROUTER TABLE ATTACHMENT SCREWS	3	28	660235010	VIS DE FIXATION DE TABLE À TOUPIE.....	3	28	660235010	TORNILLOS DEL ADITAMENTO DE MESA PARA FRESADORA	3
29	300869006	EDGE GUIDE ASSEMBLY	1	29	300869006	APPROCHER L'ASSEMBLEE DE GUIDE	1	29	300869006	BORDEE LA ASAMBLEA DE LA GUIA	1

* Standard Hardware Item – May Be Purchased Locally



R29201 Plunge Base Assembly

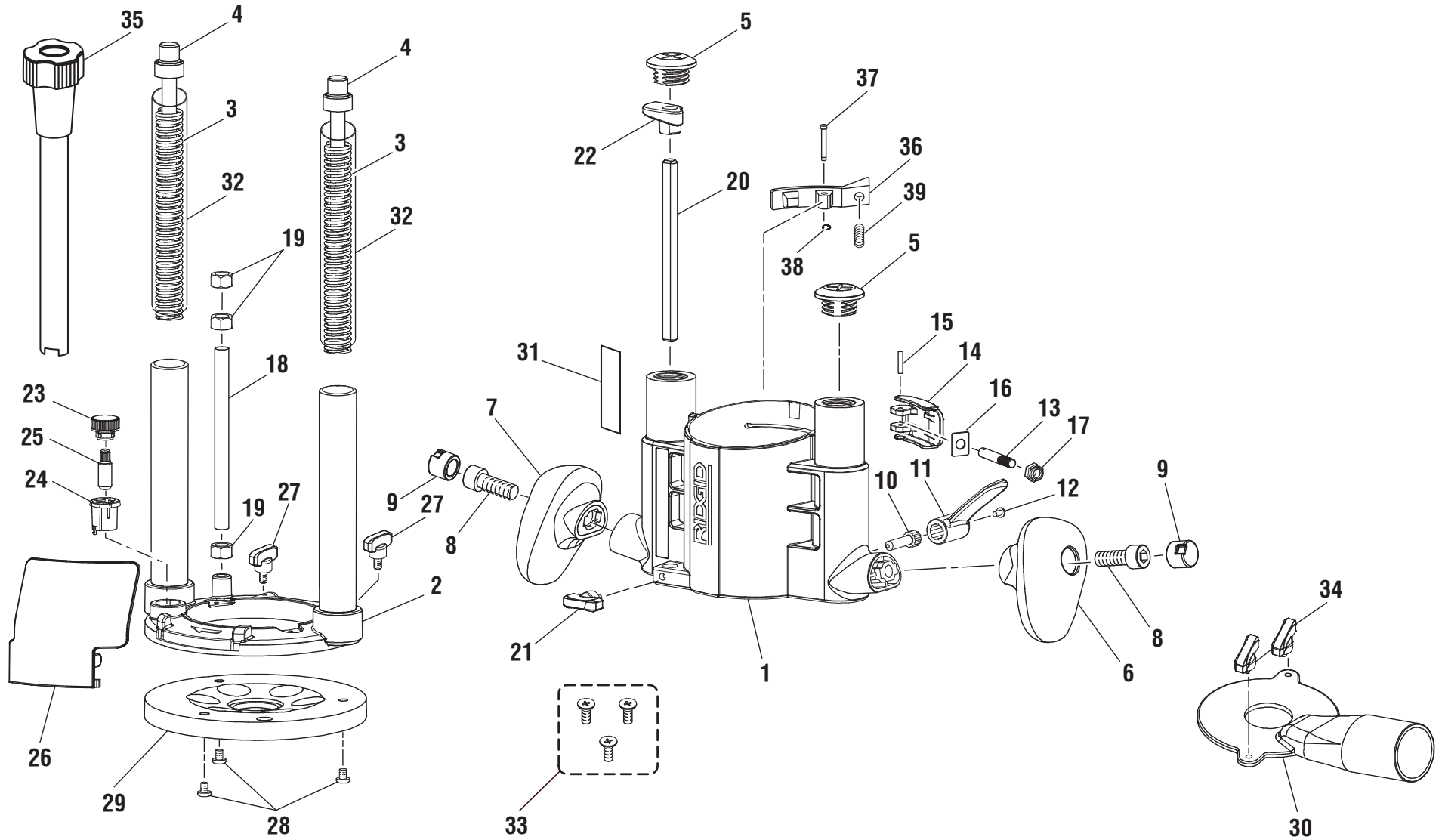

▲WARNING: The assembly shown represents an important part of the Double Insulated System. To avoid the possibility of alteration or damage to the System, service should be performed by your nearest authorized service center.

▲AVERTISSEMENT : L'ensemble illustré représente une partie importante du système à isolation double. Afin d'éviter la possibilité de modification ou de dommage au système, la réparation ne doit être effectuée que par votre centre de réparation centre commercial autorisé.

▲ADVERTENCIA: El conjunto que se ilustra representa una parte importante del Sistema de Aislamiento Doble. Para evitar la posibilidad de alteración o daño del sistema, la reparación debe ser efectuada en su centro de servicio autorizado.



R29201 Plunge Base Assembly/R29201 Base Plongeante/R29201 Conjunto de la Base Tipo Émbolo

KEY	P/N	DESCRIPTION	QTY	PIÈCE	RÉF.	DESCRIPTION	QTÉ	REF.	N/P	DESCRIPCIÓN	CANT.
1	200265003	PLUNGE FRAME ASSEMBLY.....	1	1	200265003	BÂTI DE PLONGEUR.....	1	1	200265003	BASTIDOR TIPO ÉMBOLO.....	1
2	200242004	PLUNGE BASE ASSEMBLY	1	2	200242004	BASE DE PLONGEUR	1	2	200242004	BASE TIPO ÉMBOLO	1
3	671760001	PLUNGE SPRING	2	3	671760001	RESSORT DE PLONGEUR	2	3	671760001	RESORTE DE ÉMBOLO.....	2
4	513880001	GUIDE PIN	2	4	513880001	AXE GUIDE	2	4	513880001	PASADOR GUÍA.....	2
5	513581001	PLUNGE TOWER CAP	2	5	513581001	COUVERCLE DE PLONGEUR.....	2	5	513581001	TAPA DE LA TORRE DEL ÉMBOLO.....	2
6	513347001	RIGHT HANDLE	1	6	513347001	POIGNÉE DROITE	1	6	513347001	MANGO DERECHO	1
7	513348001	LEFT HANDLE	1	7	513348001	POIGNÉE GAUCHE	1	7	513348001	MANGO IZQUIERDO	1
8	660053003	* BOLT (M10 X 28 mm SOC. HD.)	2	8	660053003	* BOULON (M10 X 28 mm À TÊTE CREUSE)	2	8	660053003	* PERNO (M10 X 28 mm CAB. HUECA) .	2
9	513395001	PLUG HANDLE	2	9	513395001	BOUCHON DE POIGNÉE	2	9	513395001	TAPÓN DEL MANGO	2
10	660427002	* SCREW (M8 X 1-1/8 in. LH.).....	1	9	513395001	BOUCHON DE POIGNÉE	2	10	660427002	* TORNILLO (M8 X 28,6 mm [1 1/8 pulg.] IZQ.).....	1
11	513610001	PLUNGE LOCK LEVER.....	1	10	660427002	* VIS (M8 X 28,6 mm [1 1/8 po] LH.).....	1	11	513610001	PALANCA DE FIJACIÓN DEL ÉMBOLO	1
12	660284003	* SCREW (6-32 X 1/4 in.).....	1	11	513610001	LEVIER DE VERROUILLAGE DE PLONGÉE	1	12	660284003	* TORNILLO (6-32 X 6,4 mm [1/4 pulg.]) .	1
13	671260001	LEVER PIN	1	12	660284003	* VIS (6-32 X 6 mm [1/4 po]).....	1	13	671260001	PASADOR DE LA PALANCA.....	1
14	200276011	LOCK LEVER	1	12	660284003	* VIS (6-32 X 6 mm [1/4 po]).....	1	14	200276011	PALANCA DE FIJACIÓN	1
15	671247001	ROLL PIN	1	13	671260001	AXE DE LEVIER.....	1	15	671247001	PASADOR DE ARTICULACIÓN	1
16	631421001	WEAR PLATE	1	14	200276011	LEVIER DE VERROUILLAGE	1	16	631421001	PLACA DE ROZAMIENTO	1
17	671243001	STOP NUT	1	15	671247001	GOUPILLE CYLINDRIQUE.....	1	17	671243001	TUERCA DE SEGURIDAD	1
18	671275001	DEPTH ADJUSTMENT ROD.....	1	16	631421001	PLAQUE D'USURE	1	18	671275001	BARRA DE AJUSTE DE PROFUNDIDAD1	1
19	660163002	HEX NUT (3/8-16)	3	17	671243001	ÉCROU DE BLOCAGE.....	1	19	660163002	TUERCA HEXAGONAL (3/8-16).....	3
20	620446001	ADJUSTMENT BAR	1	18	671275001	TIGE DE RÉGLAGE DE PROFONDEUR 1	1	20	620446001	BARRA DE AJUSTE	1
21	511129001	ADJUSTMENT BAR KNOB.....	1	19	660163002	ÉCROU SIX PANS (3/8-16)	3	21	511129001	PERILLA DE LA BARRA DE AJUSTE	1
22	513449001	DEPTH INDICATOR	1	20	620446001	BARRE DE RÉGLAGE.....	1	22	513449001	INDICADOR DE PROFUNDIDAD	1
23	380851003	PLUNGE DEPTH ADJUSTMENT KNOB	1	21	511129001	BOUTON DE BARRE DE RÉGLAGE.....	1	23	380851003	PERILLA DE AJUSTE DE PROFUNDIDAD DEL ÉMBOLO	1
24	380852001	DEPTH ADJUSTMENT GAUGE.....	1	22	513449001	JAUGE DE PROFONDEUR.....	1	24	380852001	CALIBRE DE AJUSTE DE PROFUNDIDAD.....	1
25	670583003	ADJUSTMENT SCREW/STUD.....	1	23	380851003	PROFONDEUR DE PLONGÉE BOUTON DE RÉGLAGE	1	25	670583003	TORNILLO/VÁSTAGO DE AJUSTE.....	1
26	515012001	CHIP SHIELD	1	24	380852001	JAUGE DE RÉGLAGE DE PROFONDEUR.....	1	26	515012001	PROTECTOR CONTRA VIRUTAS	1
27	512777001	GUIDE ADJUST KNOBS.....	2	25	670583003	VIS/GOIJON DE RÉGLAGE.....	1	27	512777001	PERILLAS DE LA BASE	2
28	660136002	* SCREW (10-32 X 3/8 in.).....	3	26	515012001	PARE - COPEAUX.....	1	28	660136002	* TORNILLO (10-32 X9,5 mm [3/8 pulg.]) .	3
29	513879001	SUB BASE	1	27	512777001	BOUTONS DE LA BASE	2	29	513879001	SUBBASE	1
30	513508001	VACUUM ADAPTOR.....	1	28	660136002	* VIS (10-32 X 9,5 mm [3/8 po]).....	3	30	513508001	ADAPTADOR PARA CAPTACIÓN DE POLVO	1
31	940299757	SCALE LABEL	1	29	513879001	SEMELLE	1	31	940299757	ETIQUETA DE RÈGLE.....	1
32	514481001	TUBE (PVC).....	2	30	513508001	ADAPTATEUR DE SAC À POUSSIÈRE..	1	32	514481001	TUBO (PVC)	2
33	660235010	ROUTER TABLE ATTACHMENT SCREWS.....	3	31	940299757	PLAQUETTE RÈGLE.....	1	33	660235010	TORNILLOS DEL ADITAMENTO DE MESA PARA FRESADORA	3
34	512777001	VACUUM ADAPTER SCREW.....	2	32	514481001	TUBE (PVC).....	2	34	512777001	TORNILLOS DEL ADAPTADOR DE LA ... ASPIRADORA	2
35	200438001	PLUNGE DEPTH ADJUSTMENT KNOB EXTENSION.....	1	33	660235010	VIS DE FIXATION DE TABLE À TOUPIE.	3	35	200438001	HUNDA LA EXTENSION DE LA PERILLA DEL AJUSTE DE LA PROFUNDIDAD	1
36	641431001	LATCH LEVER.....	1	34	512777001	VIS DE ADAPTATEUR D'ASPIRATION... 2	2	36	641431001	PALANCA DE PICAPORTE	1
37	672435001	PIN	1	35	200438001	PLONGER L'EXTENSION DE BOUTON D'AJUSTEMENT DE PROFONDEUR.....	1	37	672435001	PASADOR	1
38	671319001	E RING	1	36	641431001	LEVIER DE LOQUET	1	38	671319001	ANILLO EN "E"	1
39	690141002	SPRING.....	1	37	672435001	AXE	1	39	690141002	RESORTE.....	1
				38	671319001	CLIP EN E	1				
				39	690141002	RESSORT	1				

* Standard Hardware Item – May Be Purchased Locally



R29001 Motor Assembly

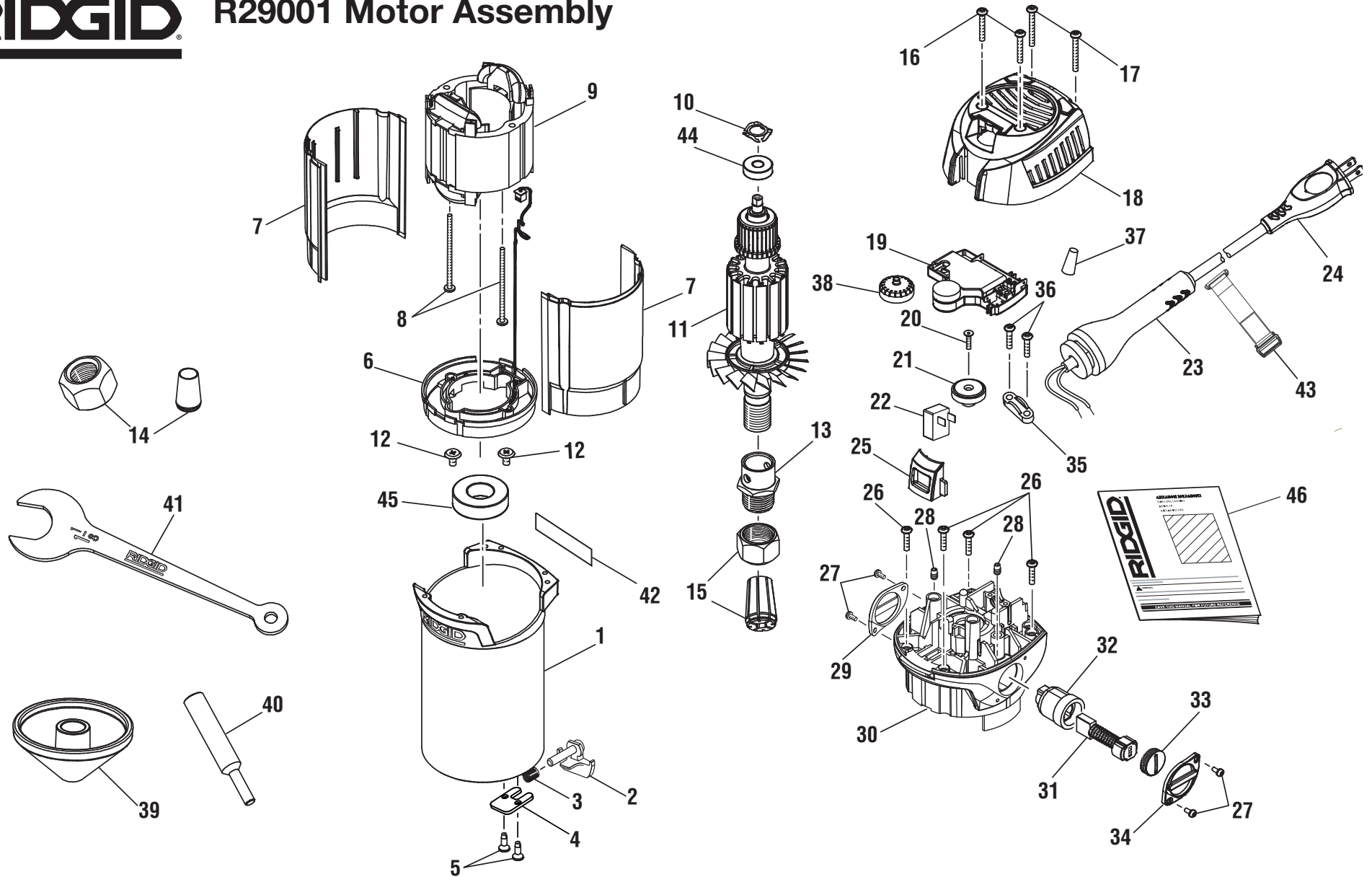

▲WARNING: The assembly shown represents an important part of the Double Insulated System. To avoid the possibility of alteration or damage to the System, service should be performed by your nearest authorized service center.

▲AVERTISSEMENT : L'ensemble illustré représente une partie importante du système à isolation double. Afin d'éviter la possibilité de modification ou de dommage au système, la réparation ne doit être effectuée que par votre centre de réparation centre commercial autorisé.

▲ADVERTENCIA: El conjunto que se ilustra representa una parte importante del Sistema de Aislamiento Doble. Para evitar la posibilidad de alteración o daño del sistema, la reparación debe ser efectuada en su centro de servicio autorizado.



R29001 Motor Assembly

KEY	P/N	DESCRIPTION	QTY	KEY	P/N	DESCRIPTION	QTY	KEY	P/N	DESCRIPTION	QTY
1	200058006	MOTOR HOUSING	1	18	340084002	TOP CAP	1	35	590924001	CORD CLAMP	1
2	515210001	SHAFT LOCK BUTTON	1	19	280013071	CIRCUIT BOARD ASSEMBLY.....	1	36	660372001	* SCREW (#6-19 X 5/8 in. PAN HD.)	2
3	690141001	SHAFT LOCK SPRING	1	20	660423002	* SCREW (M3.5 X 14 mm FLAT HD.)	1	37	870126002	WIRE NUT	1
4	631966001	COVER PLATE	1	21	301303001	ROTOR MAGNET	1	38	340338001	VARIABLE SPEED DIAL	1
5	661039001	* SCREW (8-32 X 3/8 in.).....	2	22	760385003	SWITCH	1	39	513095001	CENTERING TOOL CONE	1
6	290139020	LED TRAY ASSEMBLY.....	1	23	561365001	BEND RELIEF	1	40	671675001	CENTERING TOOL PIN	1
7	513082001	INSULATING SLEEVE	2	24	290086042	POWER CORD.....	1	41	671674001	WRENCH	1
8	660103002	* SCREW (8-10 X 2 5/8 in.).....	2	25	513086002	SWITCH ACTUATOR	1	42	940045062	DATA LABEL	1
9	740744001	FIELD	1	26	660185003	* SCREW (M4 X 16 mm PAN HD.).....	4	43	300904003	CORD WRAP	1
10	671862001	LOADING SPRING.....	1	27	660438001	* SCREW (M3 X 6 mm PAN HD.).....	4	44	680966001	BALL BEARING	1
11	200439001	ARMATURE (INC. KEY 44).....	1	28	660067001	* SCREW (8-16 X 1/4 in. TORX)	2	45	680733002	BALL BEARING (6004 VV)	1
12	660324001	* SCREW (10-32 X 3/8 in. WAFER HEAD).....	2	29	513397001	BRUSH CAP RETAINER (LH).....	1	46	987000066	OPERATOR'S MANUAL.....	1
13	671876001	BEARING RETAINER	1	30	514374001	BEARING HOUSING.....	1		901311001	BAG (NOT SHOWN).....	1
14	200150002	COLLET ASSEMBLY (1/4 in.).....	1	31	301036001	BRUSH ASSEMBLY	2				
15	200150003	COLLET ASSEMBLY (1/2 in.).....	1	32	301035001	BRUSH HOLDER ASSEMBLY	2				
16	660437003	* SCREW (M4 X 25 mm PAN HD.)	2	33	512010001	BRUSH CAP	2				
17	660437002	* SCREW (M4 X 32 mm PAN HD.).....	2	34	513400001	BRUSH CAP RETAINER (RH)	1				

* Standard Hardware Item – May Be Purchased Locally



R29001 Moteur

PIÈCE	RÉF.	DESCRIPTION	QTÉ	PIÈCE	RÉF.	DESCRIPTION	QTÉ	PIÈCE	RÉF.	DESCRIPTION	QTÉ
1	200058006	BOÎTIER DU MOTEUR.....	1	17	660437002	* VIS (M4 X 32 mm À TÊTE BOMBÉE)	2	33	512010001	CAPUCHON DE BALAI	2
2	515210001	GOUPILLE DE VERROUILLAGE D'AXE..	1	18	340084002	COUVERCLE SUPÉRIEUR	1	34	513400001	RETENUE DE CAPUCHON DE BALAI (D)1	1
3	690141001	RESSORT DE VERROUILLAGE D'AXE...1	1	19	280013071	CARTE DE CIRCUIT IMPRIMÉ	1	35	590924001	RETENUE DE CORDON	1
4	631966001	COUVERCLE	1	20	660423002	* VIS (M3,5 X 14 mm À TÊTE PLATE).....	1	36	660372001	* VIS (#6-19 X 16 mm (5/8 po) À TÊTE	1
5	661039001	* VIS (8-32 X 9,5 mm [3/8 po])	2	21	301303001	AIMANT DE ROTOR	1			BOMBÉE)	2
6	290139020	SUPPORT DEL	1	22	760385003	MICROCONTACT	1	37	870126002	RACCORD À ÉCROU	1
7	513082001	MANCHON ISOLANT	2	23	561365001	SOULAGEMENT DE CONTRAINTE.....	1	38	340338001	SÉLECTEUR DE VITESSE VARIABLE.....	1
8	660103002	* VIS (M0.170 X 66,7 mm [2 5/8 po])	2	24	290086042	CORDON D'ALIMENTATION.....	1	39	513095001	CÔNE D'OUTIL DE CENTRAGE	1
9	740744001	CHAMP	1	25	513086002	ACTIONNEUR DE COMMUTATEUR	1	40	671675001	AXE D'OUTIL DE CENTRAGE	1
10	671862001	RESSORT DE CHARGE	1	26	660185003	* VIS (M4 X 16 mm À TÊTE BOMBÉE)	4	41	671674001	CLÉ	1
11	200439001	INDUIT (COM. PIÈCE 44).....	1	27	660438001	* VIS (M3 X 8 mm À TÊTE BOMBÉE)	4	42	940045062	SAC RIGIDE EN NYLON.....	1
12	660324001	* VIS (10-32 X 9,5 mm [3/8 po])	1	28	660067001	* SCREW (#8-16 X 6 mm [1/4 po] TORX)..	2	43	300904003	PLAQUETTE SIGNALÉTIQUE	1
		VIS À TÊTE MINCE	2	29	513397001	RETENUE DE CAPUCHON		44	680966001	ROULEMENT	1
13	671876001	RETENUE DE ROULEMENT	1			DE BALAI (G).....	1	45	680733002	ROULEMENT (6004 VV)	1
14	200150002	COLLET (6 mm [1/4 po])	1	30	514374001	BOÎTIER DU ROULEMENT	1	46	987000066	MANUEL D'UTILISATION	1
15	200150003	COLLET (13 mm [1/2 po])	1	31	301036001	BALAI	2		901311001	SACOCHÉ (PAS ILLUSTRÉE).....	1
16	660437003	* VIS (M4 X 25 mm À TÊTE BOMBÉE)	2	32	301035001	PORTE-BALAI	2				



R29001 Conjunto del Motor

REF.	N/P	DESCRIPCIÓN	CANT.	REF.	N/P	DESCRIPCIÓN	CANT.	REF.	N/P	DESCRIPCIÓN	CANT.
1	200058006	ALOJAMIENTO DEL MOTOR	1	17	660437002	* TORNILLO (M4 X 32 mm CAB. TRONCOCÓNICA.)	2	34	513400001	RETÉN DE LA TAPA DE LA ESCOBILLA (DER.)	1
2	515210001	PASADOR DEL SEGURO DEL EJE	1	18	340084002	TAPA SUPERIOR	1	35	590924001	ABRAZADERA DEL CORDÓN	1
3	690141001	RESORTE DEL SEGURO DEL EJE	1	19	280013071	CONJ. DE LA PLACA DE CIRCUITOS	1	36	660372001	* TORNILLO (#6-19 X 16 mm [5/8 pulg.] CAB. TRONCOCÓNICA.)	2
4	631966001	PLACA TAPADORA	1	20	660423002	* TORNILLO (M3,5 X 14 mm CAB. PLANA)1		37	870126002	TUERCA PARA ALAMBRE	1
5	661039001	* TORNILLO (8-32 X 9,5 mm [3/8 pulg.]) ..	2	21	301303001	IMÁN DEL ROTOR	1	38	340338001	SELECTOR GIRATORIO DE VELOCIDAD	1
6	290139020	CONJ. DE LA BANDEJA DEL DIODO	1	22	760385003	MICROINTERRUPTOR	1	39	513095001	CONO DEL CENTRADOR	1
7	513082001	CAMISA AISLANTE	2	23	561365001	PROTECTOR DEL CORDÓN	1	40	671675001	ESPIGA DEL CENTRADOR	1
8	660103002	* TORNILLO (M0,170 X 66,7 mm [2 5/8 pulg.])	2	24	290086042	CORDÓN DE CORRIENTE	1	41	671674001	LLAVE	1
9	740744001	CAMPO	1	25	513086002	ACCIONADOR DEL INTERRUPTOR	1	42	940045062	ETIQUETA DE DATOS	1
10	671862001	RESORTE DE CARGA	1	26	660185003	* TORNILLO (M4 X 16 mm CAB. TRONCOCÓNICA.)	4	43	300904003	SOPORTE PARA ENROLLAR EL CORDÓN	1
11	200439001	INDUCIDO (INC. REF. 44)	1	27	660438001	* TORNILLO (M3 X 8 mm CAB. TRONCOCÓNICA.)	4	44	680966001	COJINETE DE BOLAS	1
12	660324001	* TORNILLO (10-32 X 9,5 mm [3/8 pulg.])		28	660067001	* TORNILLO (#8-16 X 6 mm [1/4 pulg.] TORX)	2	45	680733002	COJINETE DE BOLAS (6004 VV)	1
13	671876001	CABEZA DE GALLETA	2	29	513397001	RETÉN DE LA TAPA DE LA ESCOBILLA (IZQ.)	1	46	987000066	MANUAL DEL OPERADOR	1
14	671876001	RETÉN DEL COJINETE	1	30	514374001	CONJUNTO DE APOYO	1	901311001	BOLSA (NO SE MUESTRA)	1	
15	200150002	CONJUNTO DEL CASQUILLO (6 mm [1/4 pulg.])	1	31	301036001	CONJ. DE LA ESCOBILLA	2	12-04-07			
16	200150003	CONJUNTO DEL CASQUILLO (13 mm [1/2 pulg.])	1	32	301035001	CONJ. DEL PORTAESCOBILLA	2	(REV: 03)			
17	660437003	* TORNILLO (M4 X 25 mm CAB. TRONCOCÓNICA.)	2	33	512010001	TAPA DE LA ESCOBILLA	2				